

SLI1009 INDUSTRY

Technical specifications

Lifting cap. arm in/out	1000/400kg – 2200/880lb
Lifting height	4350mm / 171in
Extension of arm	830+830mm / 33+33in
Tilt	44° back / 80° fwd
Side shift	100mm / 4in
Charging voltage	230V / 110V
Charging time	Approx. 8 hrs.
Running period	Up to 10 hrs.
Front-wheel drive	2500W
Width	1020mm / 40in
Curb weight	1410kg / 3110lb

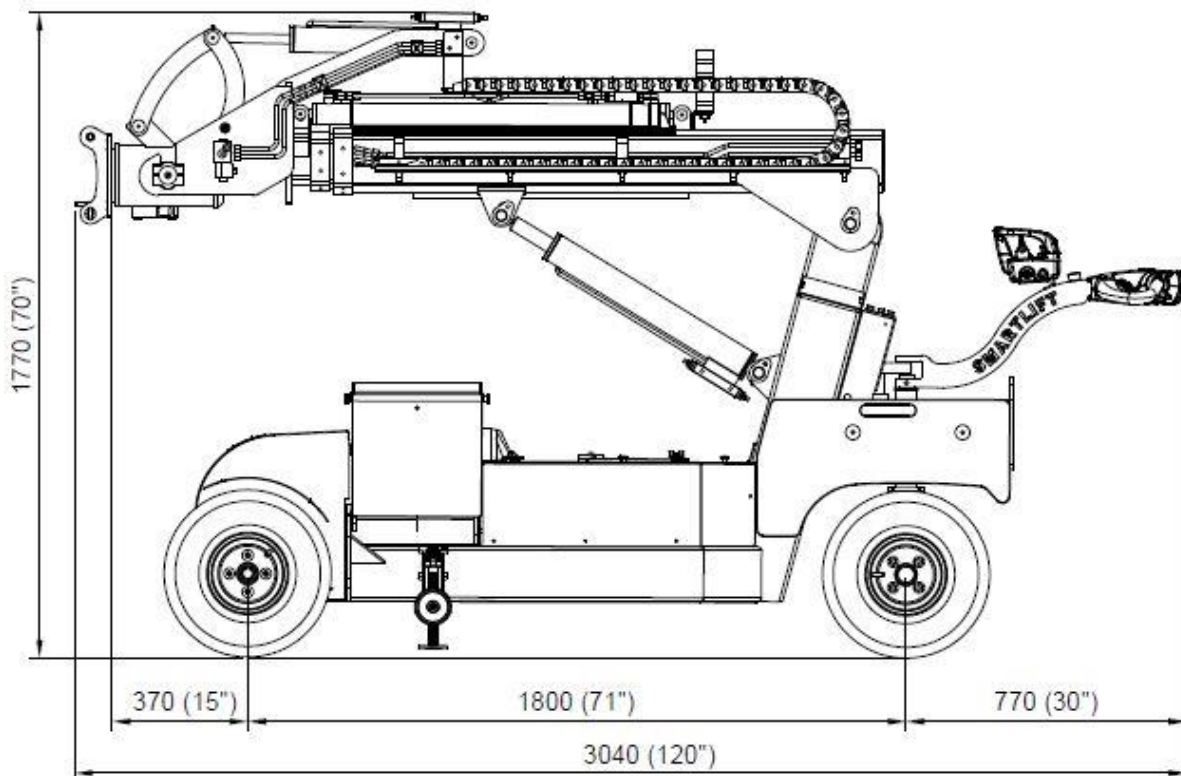
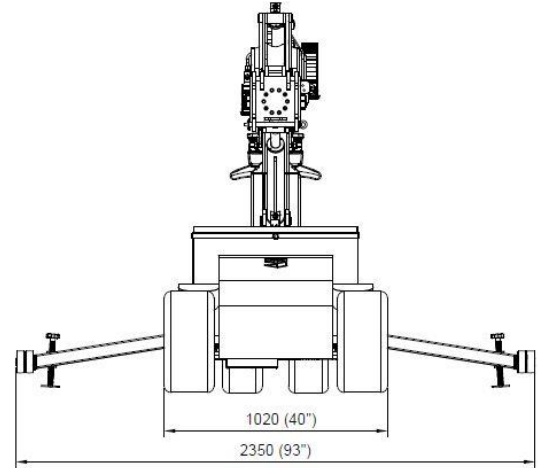

Load chart

